

# 5533A

REACH MORE  
MORE REACH

- 61 ft working height

- 33 ft maximum outreach

- Platform jib + boom extension

- Automatic leveling

- Hydraulic outriggers

Negative angle boom geometry provides industry leading working envelope.

Robust hitch with hydraulic surge brakes. Several hitch options are available to meet a large variety of needs.

Parking brake provides easy machine positioning as well as controlled maneuverability on inclines.

Heavy-duty dual foam filled jockey wheels.

Generator interface plate provides onboard storage, tie down provisions, and a convenient receptacle connection point for portable generators.

For on-site powered maneuverability a drive option allows users to operate the outriggers and drive the machine from the platform when it's in the fully-lowered position.

Beefy steel fenders and heavy-duty tires provide durable performance.

An auto-level system provides quick and easy machine set-up, from the ground control station, that can be completed in less than 30 seconds when all four outriggers are deployed simultaneously.

Hydraulic outriggers and optimized outrigger geometry provide an industry leading 12½ degree leveling capability.

Extra large, 12½ inch diameter, non-marking outrigger footpads provide excellent performance in rough terrain job sites and indoor applications on sensitive flooring.

Onboard storage for the optional material lifting hook.

Integrated forklift pockets provide the ability to forklift the machine on and off delivery vehicles.

Heavy-duty cable track system.

Lockable turntable covers protect internal components.

Pad-lockable ground control cover deters unauthorized operation.

Extension boom, platform jib, and platform are constructed from aluminum to reduce weight, allowing for maximum outreach capability.

Optional horizontal jib rotator provides increased working area and platform positioning capabilities.

4 ft (1.3m) platform jib provides an increased range of movement and platform positioning.

Self-intuitive control system provides easy machine operation from both the platform and ground control station.

Optional platform rotator provides increased working area and platform positioning capabilities.

Large 2 person platform and 500 lb (227 kg) load capacity can handle the BIG jobs.

The 19 inch (48.3 cm) entry step height provides easy access into the platform.

Quick disconnect platform and optional material lifting hook provides the ability to convert the machine into a lightweight trailer-mounted crane in seconds.

Steel cylinder guards provide superior durability.

# BIL-JAX 5533A

## Automatic Leveling System

A self-leveling system provides quick and easy set-up in less than 30 seconds.

## Hydraulic Outriggers

Optimized outrigger geometry provides industry leading leveling capability.

## Working Envelope and Outreach

The articulating boom design features an upper telescopic extension boom that can be positioned at a negative angle and a platform jib providing exceptional reach, working envelope, and platform positioning capability.

## Easy to Use

Both the platform and ground control station feature an easy-to-understand display panel with control buttons that are logically positioned around a single machine image for easy identification of button functions.

## Versatile

A quick-disconnect platform and optional Material Lifting System provides the ability to convert the machine into a light duty crane.

## Easy to Transport

The boom is easily towed with a Class 3 hitch. Convenient integrated forklift pockets are also provided.

## Standard Features

- 61 ft (18.8 m) maximum working height
- 33½ ft (10.2 m) working outreach
- 500 lb (227 kg) lift capacity
- Extension boom and platform jib
- Outrigger interlocks and tilt alarm/sensor
- Automatic leveling hydraulic outriggers
- Multiple control function speeds
- Self-leveling platform
- 110/60 GFI outlet in platform
- Surge and parking brakes
- Hour meter
- 12½-inch diameter non-marking footpads
- Heavy-duty 2-inch ball hitch

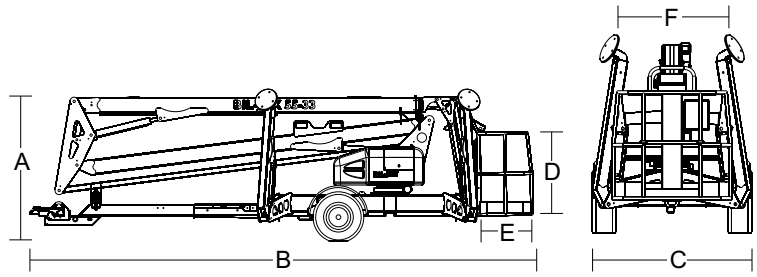

## Product Specifications

	US	Metric
Working height <sup>1</sup>	61 ft 3 in	18.8 m
Maximum platform height <sup>2</sup>	55 ft 3 in	16.8 m
Horizontal outreach		
Maximum (from centerline)	33 ft 5 in	10.2 m
Maximum (from edge of footpad)	27 ft 4 in	8.2 m
Up and over height	23 ft 1 in	7 m
Turntable rotation	700 non-continuous	
Load capacity	500 lbs	227 kg
(A) Height - stowed	78 in	198 cm
(B) Length - stowed	22 ft 11 in	7 m
(C) Width - stowed	5 ft 6 1/4 in	168 cm
(D) Height - platform	43 in	109 cm
(E) Length - platform	30 in	76 cm
(F) Width - platform	48 in	122 cm
Platform rotation (optional)	90° / manual	
Jib length	4 ft 3 in	1.3 m
Jib vertical motion	150° (+70 / -80)	
Jib rotation (optional)	180° / hydraulic	
Outrigger type	Hydraulic	
Leveling system	Auto Leveling	
Leveling capability	12 1/2°	
Outrigger footprint - length	12 ft 11 in	3.9 m
Outrigger footprint - width	12 ft 9 in	3.9 m
Footpad diameter	12 1/2 in	32 cm
Tow speed rating	65 mph	105 km/h
Tongue weight	270 lbs	122 kg
Overrun brakes	Standard	
Parking brake	Standard	
Tire size	ST 225/75 R15D	
DC power	24V DC	
Batteries	4 x 6V 245 amp-hr	
Charger	40 amp	
Total weight <sup>3</sup>	4,400 lbs	1,996 kg

<sup>1</sup> The metric equivalent of working height adds 2 m to the maximum platform height. U.S. adds 6 ft to the maximum platform height.

<sup>2</sup> Maximum platform height when outriggers are fully extended on a level surface.

<sup>3</sup> Weight will vary depending on options and/or market destination.

## Options:

- Material lifting system
- DC/Gas hybrid
- Drive and set
- Platform rotation
- Jib rotation
- Air line to platform
- Water line to platform
- Spare tire & wheel
- Tool tray
- Adjustable height combination hitch
- Various combination hitch couplers
- Custom colors

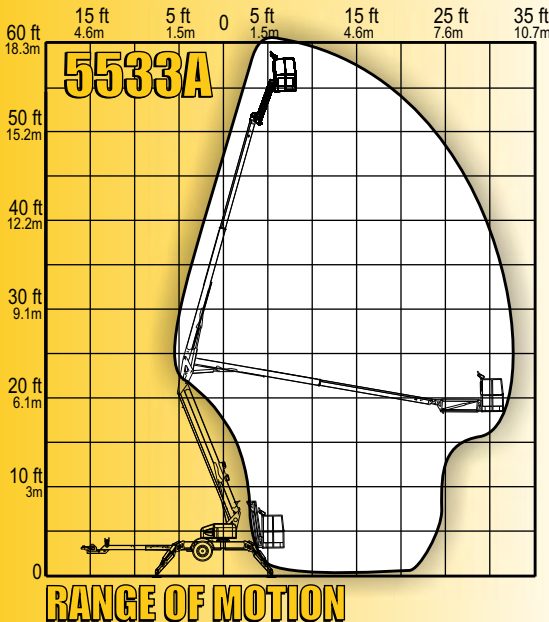

**BIL-JAX** TRAILER-MOUNTED  
A STEP ABOVE® **BOOMS**

125 Taylor Parkway  
Archbold, OH 43502-9309  
419-445-8915 / 800-537-0540  
Fax 419-445-0367 / www.biljax.com